



Onsite Wastewater Treatment Systems Technology Fact Sheet 1

Continuous-Flow, Suspended-Growth Aerobic Systems (CFSGAS)

Description

The activated sludge process is an aerobic suspended-growth process that maintains a relatively high population of microorganisms (biomass) by recycling settled biomass back to the treatment process. The biomass converts soluble and colloidal biodegradable organic matter and some inorganic compounds into cell mass and metabolic end products. The biomass is separated from the wastewater through settling in a clarifier for recycling or wasting to sludge handling processes. Preliminary treatment to remove settleable solids and floatable materials is usually provided by a septic tank or other primary treatment device. Most onsite designs are capable of providing significant ammonia oxidation and effective removal of organic matter.

The basic system consists of a number of interrelated components (as shown in figure 1):

- An aeration tank or basin.
- An oxygen source and equipment to disperse atmospheric or pressurized air or oxygen into the aeration tank at a rate sufficient to always maintain positive dissolved oxygen.
- A means to appropriately mix the aeration basin and ensure suspension of the biomass (usually accomplished by the aeration system).
- A clarifier to separate the biomass from the treated effluent and collect settled biomass for recycling to the aeration basin.

Figure 1. A basic CFSGAS configuration

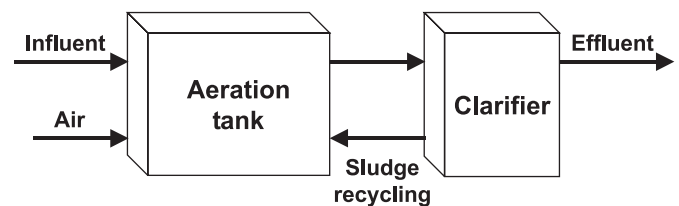

Several modifications of this basic process are commercially available. These include different aeration devices; different means of sludge collection and recycling to the aerator; the use of coarse membrane filters in lieu of, or in addition to, the clarifier; and process enhancement through the addition of an inert media area on which biofilms can grow. The addition of surfaces where biota can become attached and grow increases the capacity of the system (increased organic loading possible). This last modification is the most significant enhancement and is described below.

The combined fixed-film/suspended growth process is sometimes referred to as a class of treatment processes called coupled contact aeration, enhanced, or high biomass systems. To enhance performance and increase the capacity of the aeration tank, an inert support medium is added to the aeration tank. This allows a fixed film of biomass to attach and grow on the medium to augment the suspended microbial population, providing more biomass to feed on wastewater constituents (figure 2). Synthetic trickling filter media, loops of fiber bundles, and a variety of different plastic surface configurations can be suspended in the aeration tank. Advantages include increased active microbial mass per unit volume, enhanced potential for nitrification, reduced suspended solids loading to the clarifier, improved solids separation characteristics, reduced sludge production, and resilience under variable influent conditions.

Figure 2. An enhanced CFSGAS or “high biomass” system

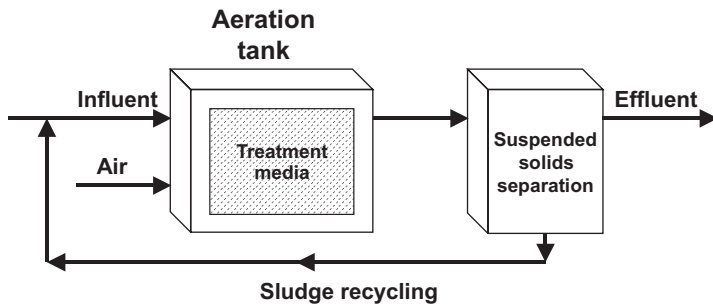

Typical application

These systems are usually preceded by a septic tank and followed by a subsurface wastewater infiltration system (SWIS). Despite some claims of reduced SWIS sizing when compared to the conventional septic tank pretreatment, the designer is cautioned to consider ground water protection. These systems should be applied only where onsite system management services are available. For surface water discharge, the system must be followed by disinfection at a minimum to consistently meet discharge standards. How-

ever, some subsurface (non-human-contact) reuse may be implemented without further treatment. High biomass systems can be a low-cost means of upgrading existing overloaded CFSGAS units that currently do not meet BOD or nitrification goals. They can also compete directly with conventional designs because they have greater stability in handling highly variable loadings.

Design assumptions

The extended aeration type of CFSGAS is the most commonly used design. At present there is no generic information on design parameters for fixed film activated sludge systems. Package plants are delivered based on design flow rates. A conservative design approach for extended aeration systems is presented in table 1. The inert medium should support additional biomass and add to the total system microbial mass. Because the increase in microbial population is difficult to measure, any “credits” for this addition would have to be based on empirical observation. Claims for significantly decreased sludge production, increased oxygen transfer efficiency, and improved settleability of the sludge have not been universally proved. However, a number of successful installations for onsite and small municipal systems have been in operation throughout the world for more than 10 years (Mason, 1977; Rogella et al., 1988; Rusten et al., 1987).

Table 1-1. Design parameters for CFSGAS extended aeration package plants

Parameter	Extended Aeration
Pretreatment (if needed)	Septic tank or equivalent
Mixed Liquor Suspended Solids (mg/L) ^a	2,000–6,000
F/M Load (lb BOD/d/MLVSS) ^b	0.05–0.15
Hydraulic Retention Time (h)	24–120
Solids Retention Time (days)	20–40
Mixing Power Input ^c	0.2–3.0 hp/1,000 ft ³
Clarifier Overflow Rate (gpd/ft ²)	200–400 avg., 800 peak
Clarifier Solids Loading (lb/d/ft ²)	30 avg., 50 peak
Dissolved Oxygen (mg/L)	>2.0
Residuals Generated	0.6–0.9 lb TSS/lb BOD removed
Sludge Removal	3–6 months as needed

^aTSS in aeration tank.

^bOrganic loading (pounds of BOD per day) to aeration tank volatile fraction of MLSS.

^cPower input per cubic foot of tank volume.

Figure 3. Components of a typical aerobic treatment unit

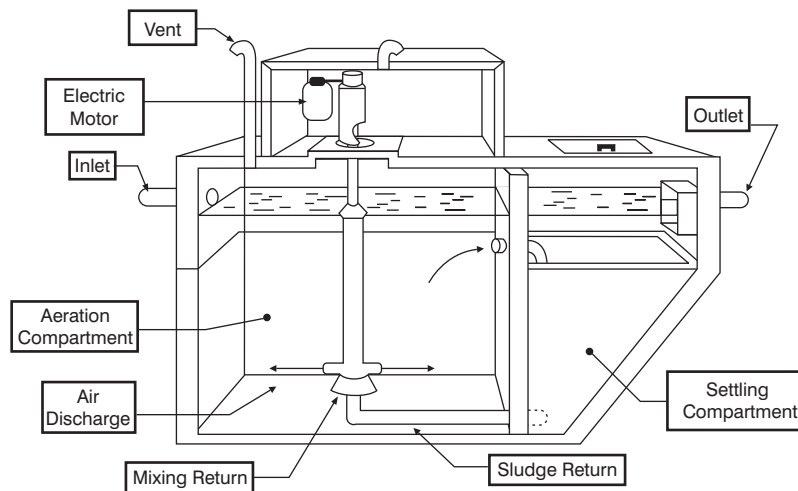

Onsite package treatment units (see figure 3) should be constructed of noncorrosive materials, such as coated concrete, plastic, fiberglass, or coated steel. Units may be stand-alone or manufactured to drop into a compartmented septic tank. Some units are installed aboveground on a concrete slab with proper housing to protect against severe climatic conditions. Units may also be buried underground as long as easy access is provided to all mechanical parts, electrical control systems, and water surfaces. All electrical components should follow NEC code and be waterproof and/or housed from the elements. If airlift pumps are used, large-diameter units should be provided to avoid clogging. Blowers, pumps, and other mechanical devices should be designed for continuous use because they will be abused by climatic conditions and the corrosive atmosphere within the treatment environment. Easy access to all moving parts should be provided for routine maintenance. An effective alarm system should be employed. Typical land area requirements for package plants are modest.

For engineered package plants, final clarifier designs should be conservative for high MLSS and poor settleability of biomass. Because of the potential for bulking sludge, secondary clarifiers should be equipped with surface skimming devices to remove greases and floating solids, as well as efficient screens.

Performance

Well-operated CFSGAS extended aeration units that are well operated can achieve BOD concentrations ranging from 10 to 50 mg/L and TSS concentrations ranging from 15 to 60 mg/L. Some studies (Brewer et al., 1978; Hutzler et al., 1978) have indicated poorer performance owing to surge flows, variable loading, and inadequate maintenance. Nitrification can also be significant in these aeration units during warmer periods. Some nitrogen removal can be achieved by denitrification, which can remove 30 to 40 percent of the total nitrogen (TN) under optimum conditions. Average total nitrogen effluent concentrations in residential extended aeration units range from 17 to 40 mg/L. Fecal coliform and virus removal has been reported in the range of 1 to 2 logs.

High biomass systems have produced BOD and TSS effluents of 5 to 40 mg/L. Although they are less dependent on temperature than the extended aeration CFSGAS, temperature does have an impact on their seasonal capability to nitrify the influent ammonium-nitrogen to nitrate-nitrogen. All CFSGAS systems do an excellent job of removing toxic organics and heavy metals. Most CFSGAS systems do not remove more than a small percentage of phosphorus (10 to 20 percent) and nitrogen (15 to 25 percent).

Management requirements

CFSGAS systems must be managed and maintained by trained personnel rather than homeowners to perform acceptably. Power requirements vary from 2.5 to 10 kWh/day. They should be inspected at least every 2 to 3 months. During these inspections, excess solids pumping should be based on the mixed liquor measurements. It is estimated that an effective program will require between 12 and 28 person-hours annually, in addition to analytical testing of the effluent, where required. Management contracts should be in place for the life of the system. Common operational problems with extended aeration systems are provided in table 2. Residuals generated will vary from 0.6 to 0.9 lb TSS per lb BOD removed, over and above the normal septic tank sludge produced.

Table 1-2. Common operational problems of extended aeration package plants

Observation	Cause	Remedy
Excessive local turbulence In aeration tank	Diffuser plugging Pipe breakage Excessive aeration	Remove and clean Replace as required Throttle blower
White, thick, billowy foam on aeration tank	Insufficient MLSS	Avoid wasting solids
Thick, scummy, dark tan foam on aeration tank	High MLSS	Waste solids
Dark brown/black foam and mixed liquor in aeration tank	Anaerobic conditions Aerator failure	Check aeration system, aeration tank DO
Billowing sludge washout in clarifier	Hydraulic or solids overload Bulking sludge	Waste sludge; check flow to unit See EPA, 1977
Clumps of rising sludge in clarifier	Denitrification Septic conditions in clarifier	Increase sludge return rate to decrease sludge retention time in clarifier Increase return rate
Fine dispersed floc, turbid effluent	Turbulence in aeration tank Sludge age too high	Reduce power input Waste sludge
Poor TSS and/or BOD removal	Excess flow and strength variations	Install flow smoothing system
Poor nitrification	Low temperatures Excessive biocide use	Insulate, upgrade to high biomass, etc. Reduce biocide loading

Risk management issues

CFSGAS systems require effluent disinfection at a minimum to meet surface discharge or any surface reuse water quality requirements. They are quite sensitive to temperature, interruption of electric supply, influent variability, or shock loadings of toxic chemicals. The septic tank helps protect these units from the latter problems. Aesthetically, noise from the blowers is the major irritant, while odors can be significant during power outages or organic overloading periods. High biomass units are more resistant to the above impacts. The systems are not well suited to seasonal use because of long start-up times.

Costs

The installed costs of package plants are highly variable but are usually less than \$10,000. Operation and maintenance (O/M) costs are primarily dependent on local power and labor costs, varying from \$400 to \$600 per year in most cases.

References

- Ayres Associates. 1998. *Florida Keys Onsite Wastewater Nutrient Reduction Systems Demonstration Project*. Contract no. LP 988. Florida Department of Health Onsite Sewage Program, Tallahassee, FL.
- Brewer, W.S., J. Lucas, and G. Prascak. 1978. An evaluation of the performance of household aerobic sewage treatment units. *Journal of Environmental Health* 41(2):82-84.

- Converse, J.C., and M.M. Converse. 1998. Pump Chamber Effluent Quality Following Aerobic Units and Sand Filters Serving Residences. In *Proceedings of the Eighth National Symposium on Individual and Small Community Sewage Systems*. American Society of Agricultural Engineers, Orlando, FL.
- Englehardt, J.D., and R.C. Ward. 1986. Operation and maintenance requirements for small flow treatment systems. *Journal of the Water Pollution Control Federation* 58(10).
- Hutzler, N.L., L. Waldorf, and J. Fancy. 1978. Performance of Aerobic Treatment Units. In *Proceedings of the Second National Home Sewage Treatment Symposium*. American Society of Agricultural Engineers, Chicago, IL.
- Kellam, J.G., et al. 1993. *Evaluation of Performance of Five Aerated Package Treatment Systems*. Bull. 178. Virginia Water Resources Research Center, Blacksburg, VA.
- Mason, D.G. 1977. A Unique Biological Treatment System for Small Plants. Paper presented at the 50th Water Pollution Control Federation Conference, Philadelphia, PA.
- Midwest Plan Service. 1982. *On-site Domestic Sewage Disposal Handbook*. Midwest Plan Service, University of Minnesota, St. Paul, MN.
- Otis, R.J., and W.C. Boyle. 1976. Performance of single household treatment units. *Journal of Environmental Engineering Division*, ASCE, 102, EE1, 175.
- Otis R.J., et al. 1975. The Performance of Household Wastewater Treatment Units under Field Conditions. In *Proceedings of the Third National Home Sewage Disposal Symposium*. American Society of Agricultural Engineers, Chicago, IL.
- Rogella, F., J. Sibony, G. Boisseau, and M. Benhomme. 1988. Fixed Biomass to Upgrade Activated Sludge. Paper presented at 61st Annual Water Pollution Control Federation Conference, Philadelphia, PA.
- Rusten, B., M.J. Tetreault, and J.F. Kreissl. 1987. Assessment of Phased Isolation Ditch Technologies for Nitrogen Control. In *Proceedings of the Seventh European Sewage and Refuse Symposium*, pp. 279-291, Munich, Germany.
- Tchobanoglous, G., and F. Burton. 1991. *Wastewater Engineering*. 3rd ed. McGraw-Hill, Inc., New York.
- U.S. Environmental Protection Agency (USEPA). 1978. *Management of Small Waste Flows*. Small Scale Waste Management Project. EPA 600/2-78-173. National Technical Information Service PB 286 474.
- U.S. Environmental Protection Agency (USEPA). 1980. *Design Manual: Onsite Wastewater Treatment and Disposal Systems*. EPA 625/1-80-012. U.S. Environmental Protection Agency, Office of Water Programs, Washington, DC.

